

## YDS-MAA29-S5K3P8 V1.0

### 16MP Samsung S5K3P8 MIPI-Schnittstelle Autofokus Kameramodul



Vorderansicht



Rückansicht

#### Spezifikationen

<b>Kameramodul Nr.</b>	<b>YDS-MAA29-S5K3P8 V1.0</b>
<b>Auflösung</b>	16MP
<b>Bildsensor</b>	S5K3P8
<b>Sensorart</b>	1/3.1"
<b>Pixel Größe</b>	1.0 um x 1.0 um
<b>EFL</b>	3.81 mm
<b>F.NO</b>	2.20
<b>Pixel</b>	4640 x 3488
<b>Betrachtungswinkel</b>	76.8°(DFOV) 62.7°(HFOV) 48.7°(VFOV)
<b>Linsenabmessungen</b>	8.50 x 8.50 x 5.60 mm
<b>Modulgröße</b>	20.85 x 8.50 mm
<b>Modultyp</b>	Autofokus
<b>Schnittstelle</b>	MIPI
<b>Autofokus-VCM-Treiber-IC</b>	CN3927E
<b>Linsenmodell</b>	YDS-LENS-60183A1
<b>Linsentyp</b>	650 nm IR-Schnitt
<b>Betriebstemperatur</b>	-30°C to +70°C
<b>Gegenstecker</b>	BBR43-30KB533

## YDS-MAA29-S5K3P8 V1.0

16MP Samsung S5K3P8 MIPI-Schnittstelle Autofokus Kameramodul



Ansicht von oben



Seitenansicht

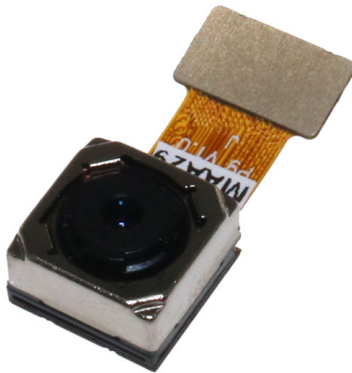

Untersicht

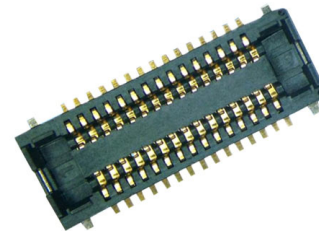

Gegenstecker

Version	Information	Date
V1.0	First Version	4-24-2022

RoHS	
0	SIGNAL
1	GND
2	GND
3	GND
4	GND
5	AFVDD2.8V
6	NC
7	SDA
8	DOVDD1.8V
9	SCL
10	DVDD1.0V
11	GND
12	XSHUTDOWN
13	MCN
14	NC
15	MCP
16	GND
17	MDO0N
18	MCLK
19	MD0P
20	GND
21	MD1N
22	FLASH
23	MD1P
24	AVDD2.8V
25	NC
26	AGND
27	MD2N
28	MD3N
29	MD2P
30	MD3P

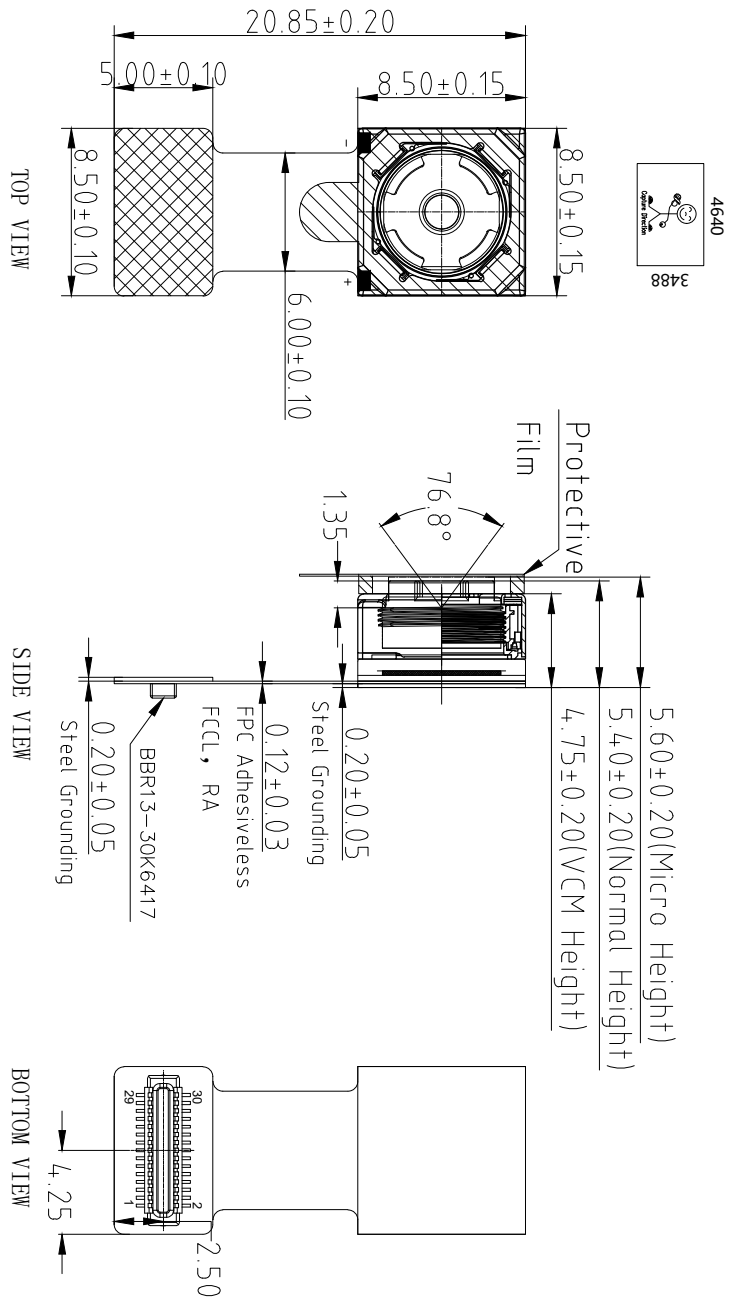

**NOTE:**

1.The device slave address:0x20;

**Parameters:**

**1、Sensor specification:**

Image Sensor: S5K3P8  
 Pixel: 1.0umx1.0um  
 Lens Type: 1/3.1  
 Important Voltage Description: DVDD1.0V  
 (external power supply);

**2、Lens specification:**

FOV: 76.8°(D),62.7°(H),48.7°(V);  
 F/NO.: 2.2  
 TV distortion: <1.5%  
 Focal length: 3.81mm  
 Composition: 6P+IR FILTER  
 IR Cut Coating: 650nm±10nm@50%

Designed By	Kevin	Model Name:	MAA29-S5K3P8 V1.0		
Checked By	Aouly__Yan	Projection Type:	Unit:	Material:	
		Third Angle	mm	-----	
			Scale:	Sheet:	Version:
			1:1	1 of 1	1/0

# S5K3P8SX03

**1/3.1" 16Mp CMOS Image Sensor for supporting SWDR and PD-AF Pattern**

**Revision 1.02**

**May 2016**

**SAMSUNG Confidential**  
avp-electronics / cissz at 2016.06.16

## Data Sheet

SAMSUNG ELECTRONICS RESERVES THE RIGHT TO CHANGE PRODUCTS, INFORMATION AND SPECIFICATIONS WITHOUT NOTICE.

Products and specifications discussed herein are for reference purposes only. All information discussed herein is provided on an "AS IS" basis, without warranties of any kind.

This document and all information discussed herein remain the sole and exclusive property of Samsung Electronics. No license of any patent, copyright, mask work, trademark or any other intellectual property right is granted by one party to the other party under this document, by implication, estoppel or otherwise.

Samsung products are not intended for use in life support, critical care, medical, safety equipment, or similar applications where product failure could result in loss of life or personal or physical harm, or any military or defense application, or any governmental procurement to which special terms or provisions may apply.

For updates or additional information about Samsung products, contact your nearest Samsung office.

All brand names, trademarks and registered trademarks belong to their respective owners.

© 2016 Samsung Electronics Co., Ltd. All rights reserved.

# 1 Product Overview

## 1.1 Introduction

The S5K3P8SX is a highly integrated 16M pixel camera chip that includes a CMOS image sensor (CIS), image correction functionality and serial transmission using 4-lane MIPI. It is designed for fast yet low power operation, delivering full resolution capture at 30 frames per second (fps) and full field of view (16:9) FHD video at 60fps.

The S5K3P8SX supports Wide Dynamic Range (WDR) image capturing at both video and still modes, allowing high quality image capturing in cases of mixed lightening scenes. It also supports Phase Detection Auto Focus (PD AF) mechanism allowing efficient Auto Focus in the system.

It is fabricated by the SAMSUNG 65nm back side illumination (BSI) CMOS image sensor process developed for imaging applications to realize a high-efficiency and low-power photo sensor. The sensor consists of 4640 x 3488 effective pixels that meet with the 1/3.1-inch optical format.

The CIS has on-chip 10-bit ADC arrays to digitize the pixel output and on-chip Correlated Double Sampling (CDS) to drastically reduce Fixed Pattern Noise (FPN). It incorporates on-chip camera functions such as defect correction, exposure setting, white balance setting and image data compression.

The S5K3P8SX CIS is programmable through a CCI or SPI serial interface and includes on-chip one-time programmable (OTP) non-volatile memory (NVM).

The S5K3P8SX is suitable for a low-power camera module with a 2.8V/1.0V power supply.

## 1.2 Features

- 16Mp sensor with 1/3.1" optics
- Unit Pixel Size : 1.0 um
- Effective Resolution : 4640(H) x 3488(V)
- Active Resolution : 4656(H) x 3504(V)
- Color Filter : RGB Bayer Pattern
- Shutter Type : Electronic Rolling Shutter
- Max. Normal Frame Rate : 30fps@Full
- Max. Video Frame Rate : 60fps@1080p, 120fps@720p, 120fps@WVGA
- Data rate : 1500Mbps/lane
- ADC Accuracy : 10bits
- Wide Dynamic Range (WDR) image capturing support
- Phase Detection Auto Focus (PDAF) support
- PDAF tail mode support
- Interfaces :
  - Fine interface frequency control using additional dedicated PLL for EMI avoidance and integration flexibility.
  - MIPI CSI-2 four lanes (1.5Gbps per lane)
  - Output formats - RAW8 (using DPCM/PCM compression), RAW10
- Control interface :
  - I2C-compatible - Two-wire serial communication circuit up to 400 KHz
    - In Fast-mode Plus(Fm+) up to 1Mhz (External Clock >= 24Mhz)
  - SPI interface - Three-wire serial communication circuit up to 10MHz
- 32 Kbit on-chip OTP memory to support defect corrections and Chip ID
- Analog gain x16
- Vertical flip and horizontal mirror mode
- Continuous frame capture mode
- 2/2, 3/3, 4/4, 6/6 - average/average-sub-sampling readout
- Pixel elimination readout function
- Bad pixel correction
- Built-in test pattern generation
- Supply voltage : 2.8V for analog, 1.8V for I/O  
1.0V digital core supply for normal mode
- Operating temperature : -30°C to +70°C

# CN3927E

## Low Cost Voice Coil Motor Driver with I2C interface

### 1. Description

The CN3927E is a low cost single 10-bit DAC with 120mA output current sink capability. Designed for linear control of voice coil motors, the CN3927E is capable of operating voltage from 2.3V to 5.5V. The DAC is controlled via a I2C serial interface that operates DAC by clock rates up to 400kHz.

The CN3927E incorporates with a UVLO reset circuit, power-down function, and exactly matched sense resistor. UVLO reset circuit ensure when supply power up, DAC output is to 0V until valid write-bit value takes place. It has a power down features that reduces the current consumption of the device to 1uA maximum.

The CN3927E is designed for auto focus and optical zoom camera phones, digital still cameras, and camcorders applications. The I2C address for the CN3927E is 0x18.

### Features

- WLCSP package for minimum footprint
- Ramp control circuit
- Fixed I<sup>2</sup>C logic thresholds
- 10-bit D-to-A converter
- 117μA *I<sub>out</sub>* resolution
- I2C serial interface (1.8V input available)
- Low current sleep mode
- 2.3 to 5.5 V power supply

### Applications

- Digital camera
- Cell phone
- Lens auto focus
- Web camera

### Package:

- 6-Bump Chip Scale Package
- 0.70mm(W) x1.10mm(H) x 0.28mm(T)
- 0.4mm Bump Pitch



### 2. Functional Block Diagram

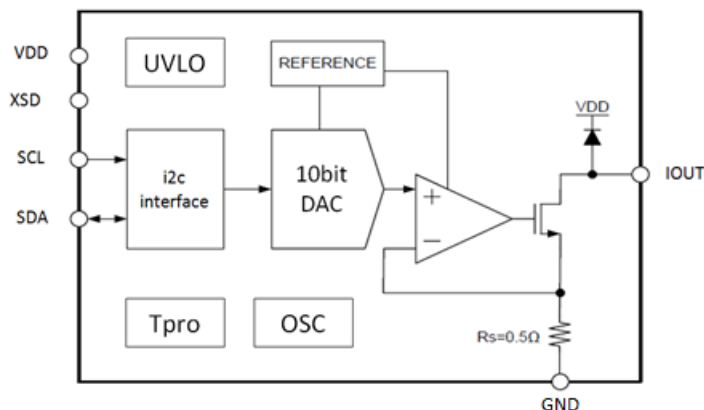

**3. Pin Assignments**

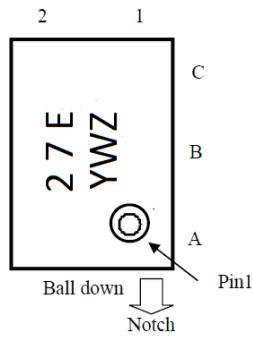
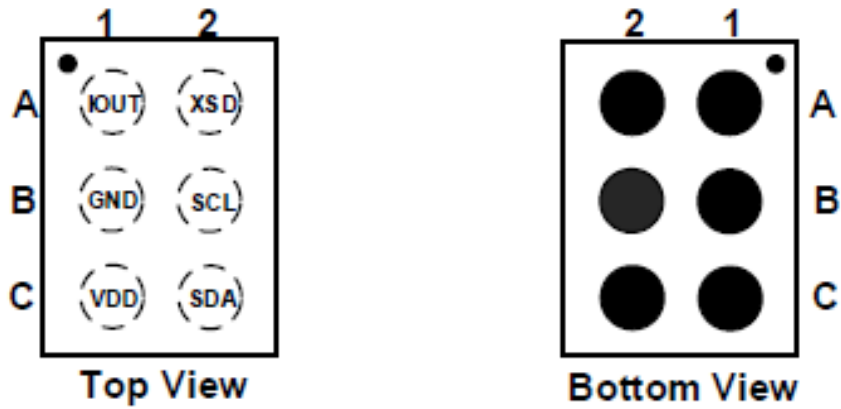

**4. Pin Description**

Pin Name	Pin Number	Description
IOUT	A1	Sink Drive Output
XSD	A2	Standby Mode Control
GND	B1	Ground
SCL	B2	I <sup>2</sup> C clock
VDD	C1	Power Supply In
SDA	C2	I <sup>2</sup> C data

**5. Ordering Information**

Order Part Number	Top Marking	Pb-Free	T <sub>A</sub>	Package	
CN3927E	27E	Yes	-40 to +85°C	WLCSP6	Tape & Reel, 3K



## 6. Absolute Maximum Ratings

Stresses beyond those listed under “Absolute Maximum Rating” may cause permanent damage to the device. These are stress ratings only and functional operation of the device at these or any other condition beyond those indicated in the operational sections of the specifications is not implied. Exposure to absolute maximum rating conditions for extended periods may affect device reliability.

Parameter		Conditions	Min.	Typ	Max.	Unit
Supply Voltage	VDD				6.5	V
Logic Input Voltage Range	Vin		-3		Vdd+0.3	V
Junction Temperature	Tj				150	°C
Storage Temperature Range	Ts		-40		150	°C
Operating Temperature Range			-40		85	°C
ESD (HBM)				6		KV
CN3927E	Rja	4 layer PCB			64	°C/W

## 7. Recommend Operating Conditions

The Recommended Operating Conditions table defines the conditions for actual device operation to ensure optimal performance to the datasheet specifications. CHIPNEXT does not recommend exceeding them or designing to Absolute Maximum Ratings.

Parameter	Min.	Typ.	Max.	Unit
Supply Input Voltage	2.3	3	5.5	V
Junction Temperature Range	-40		125	V
Ambient Temperature Range	-40		85	°C

## 8. Electrical Characteristics

T<sub>A</sub> = 25°C, VDD=2.8V, (unless otherwise specified)

Characteristics	Symbol	Test Conditions	Limits			
			Min.	Typ.	Max	Units
Supply Current	Ivdd	Code=0		0.2		mA
		Sleep Mode (XSD=Low),			1	uA
		Software PD Mode , PD=1,			1	uA
UVLO VDD threshold	Vth_uvlo	Iout<1uA, when VDD decrease to Vth_uvlo			2.15	V
UVLO hysteresis	Vhys_uvlo			100		mV

## YDS-LENS-60183A1

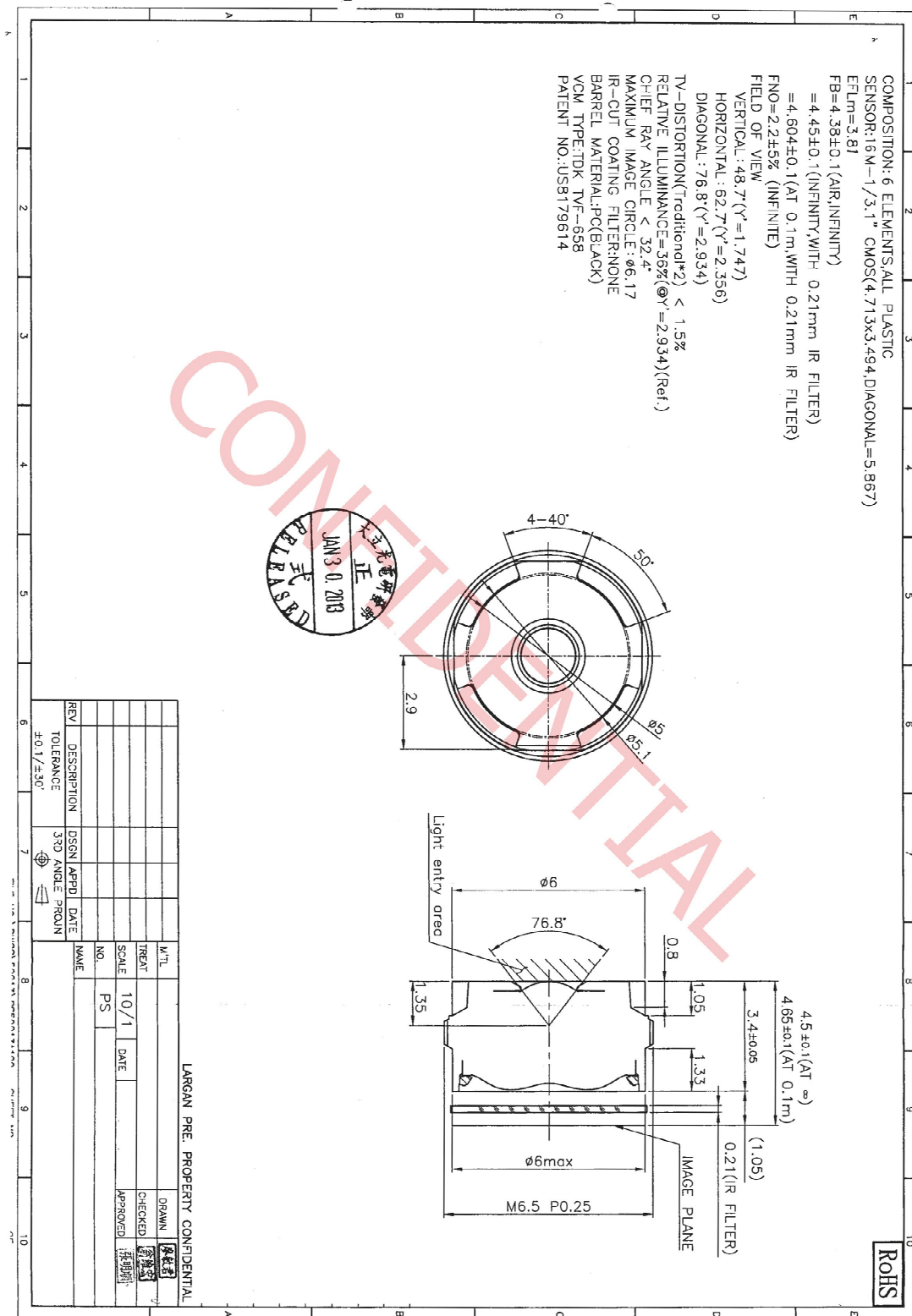

1 2 3 4 5 6 7 8

REV.	EC#	DESCRIPTION	DATE	DRAWN	CHECKED	APPROVED
A	TJECR10018-02	NEW RELEASE PER NPRI 0009	11/05/10'	RAIN	DICK, SON	HARDWARE
B	TJECR13014	AXI, AXI	05/13/13'	RAIN	SteveM	eng
					Jeff	eng

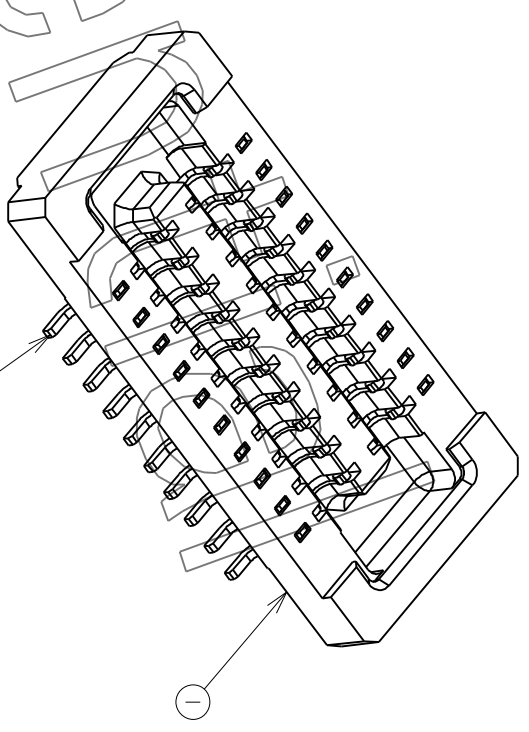
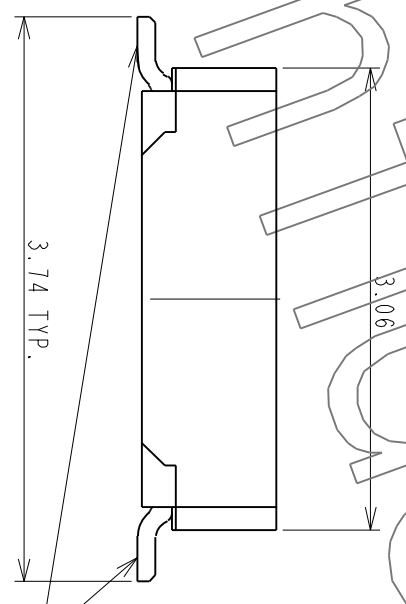
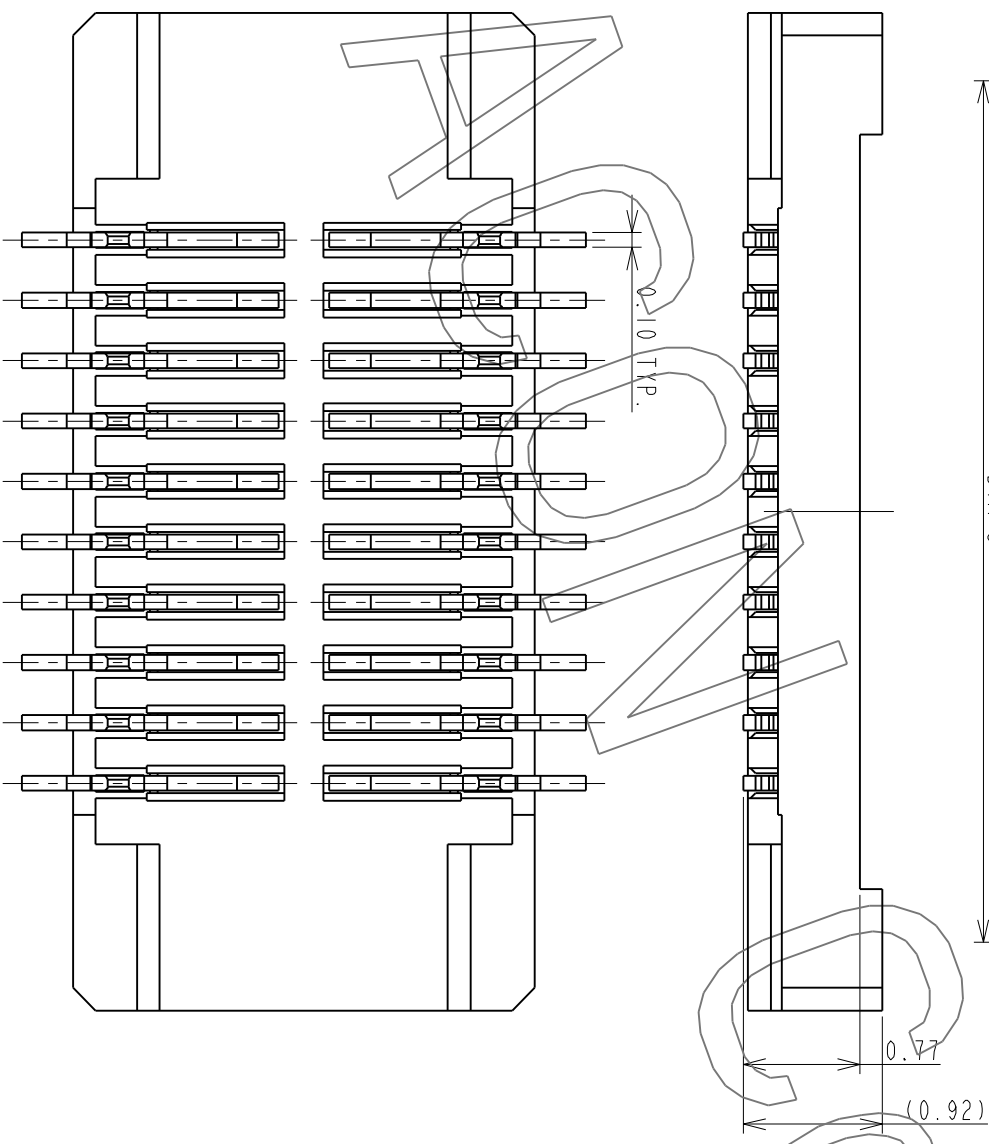
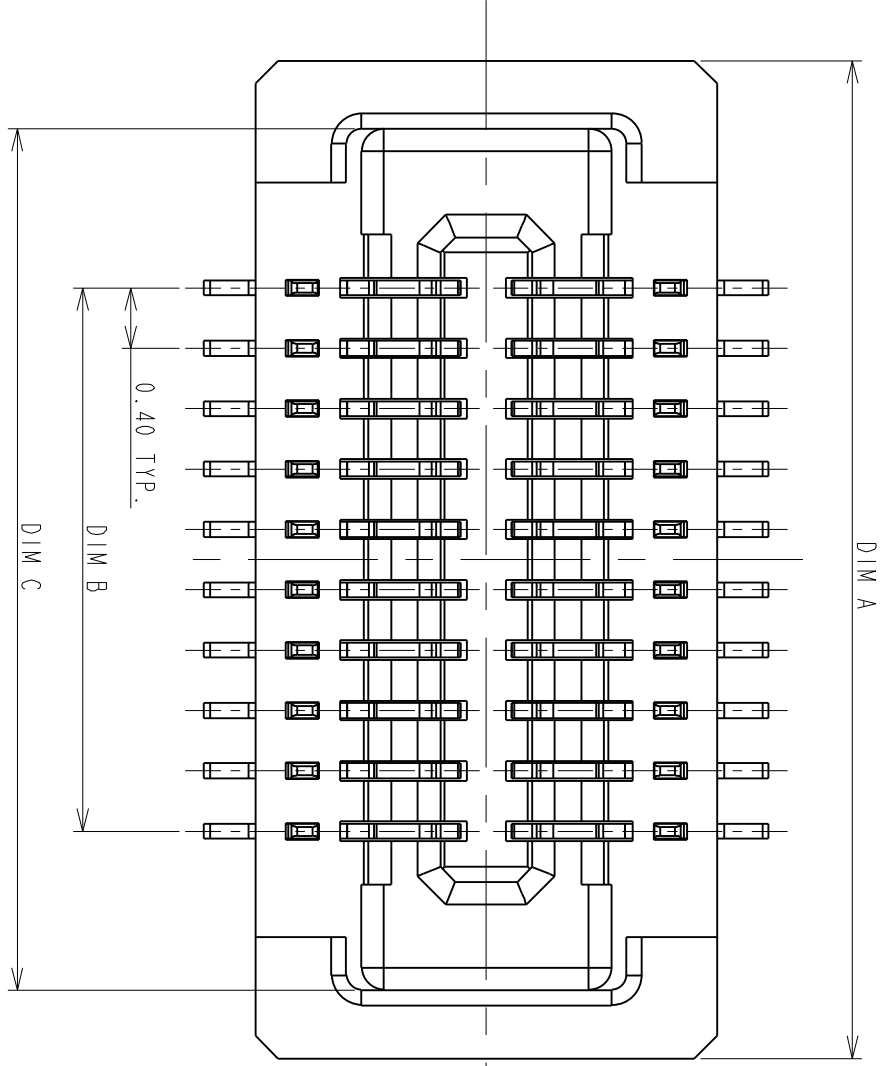

0.08  
ALL OF PLACES

ITEM	NAME	Q'TY	PART #	MATERIAL / FINISH
2	CONTACT	XX	T-BBR43-100X30	COPPER ALLOY/PLATING GOLD
1	HOUSING	1	I-BBR43-1XXX33	HIGH TEMP RESIN/UL 94 V-0

TOLERANCES UNLESS OTHERWISE SPECIFIED	
GENERAL	.XX ±0.38
DESIGN	.XXX ±0.25
RAIN	±0.05
CHECKED	DATE
HARDWARE	DATE
APPROVED	DATE
DICK, LEE	04/24/10'

SCALE	TITLE
20:1	P0.4*H1.0mm BOARD TO BOARD CONN. RECEPTACLE WITHOUT HOLD DOWN
SHEET 1 OF 2	
UNIT	
MM	
<b>CUSTOMER DRAWING</b>	
DWG NO.	C-BBR43-04-01
REV.	B
SERIES	BBR
SIZE	A3



This document and information contained herein are the property of Advanced Connectek Inc. Copies are issued in strict confidence and shall not be reproduced or copied, or used as the basis of manufacture or sale of apparatus without permission.

All materials meet the ACON's spec. environment-related substances management technical standard

F E D C B A

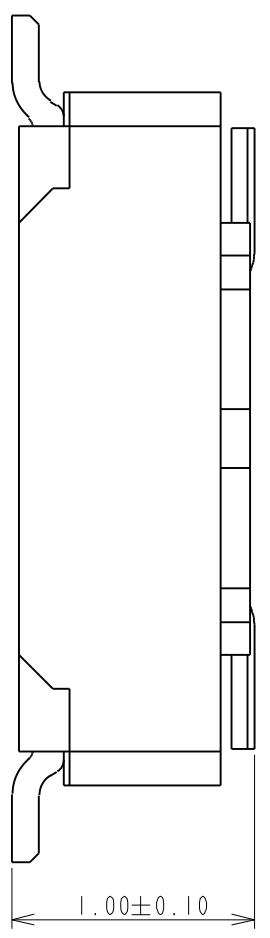

PRODUCT NUMBERING CODE:  
 BBR43 - XX K X 5 X X  
 1 2 3 4 5 6 7

1. PRODUCTION CODE:  
 BBR43: BOARD TO BOARD 0.4 PITCH RECEPTACLE

2. POSITIONS:  
 XX: POSITIONS(SEE TABLE A)

3. INSULATOR COLOR:  
 K: BLACK

4. CONTACT PLATING:  
 1: GOLD 1u" MIN  
 2: GOLD 5u" MIN  
 3: GOLD 10u" MIN  
 B: GOLD 4u" MIN FOR SPOT PLATING  
 ALL OVER: NI 50~100u"

5. TYPE OF HEIGHT:  
 5: H=0.77mm

6. TYPE OF HOLD DOWN:  
 3: WITHOUT HOLD DOWN

7. OTHER  
 2: WITH POST, FINISHED PRODUCTS  
 3: WITHOUT POST, FINISHED PRODUCTS

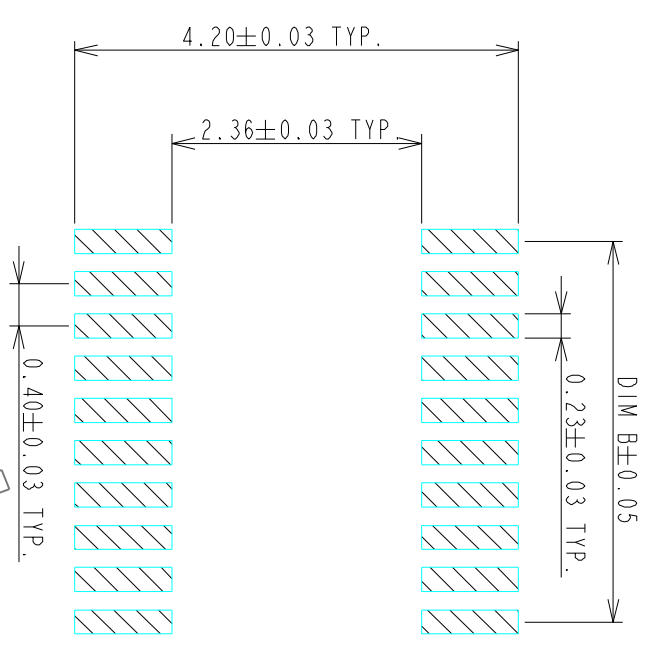

RECOMMENDED P.C. BOARD PATTERN DIMENSION (WITHOUT HOLD DOWN)

NOTES:  
 1.0: RATING:  
 1.1: VOLTAGE: 60V AC/DC  
 1.2: CURRENT: 0.5 AMPS  
 1.3: OPERATION TEMPERATURE: -40°C TO +85°C

2.0: ELECTRICAL CHARACTERISTIC:  
 2.1: CONTACT RESISTANCE: 50 mΩ MAX INITIAL  
 2.2: INSULATION RESISTANCE: 1000 MΩ MIN INITIAL  
 2.3: DIELECTRIC WITHSTANDING VOLTAGE: 250V AC FOR ONE MINUTE

3.0 TOLERANCES UNLESS OTHERWISE SPECIFIED

GENERAL: DIMENSION >10.00 ±0.13  
 DIMENSION 5.00~10.00 ±0.10  
 DIMENSION <5.00 ±0.05

TABLE A:

POSITIONS	DIM A	DIM B	DIM C
10	4.61	1.60	3.71
14	5.41	2.40	4.51
16	5.81	2.80	4.91
18	6.21	3.20	5.31
20	6.61	3.60	5.71
22	7.01	4.00	6.11
24	7.41	4.40	6.51
26	7.81	4.80	6.91
30	8.61	5.60	7.71
32	9.01	6.00	8.11
34	9.41	6.40	8.51
40	10.61	7.60	9.71
44	11.41	8.4	10.51
48	12.21	9.20	11.31
50	12.61	9.60	11.71
54	13.41	10.40	12.51
60	14.61	11.60	13.71
70	16.61	13.60	15.71
80	18.61	15.60	17.71

4.0 ALL COPPLANARITY IS 0.08mm MAX. BEFORE REFLOW  
 ALL COPPLANARITY IS 0.10mm MAX. AFTER REFLOW

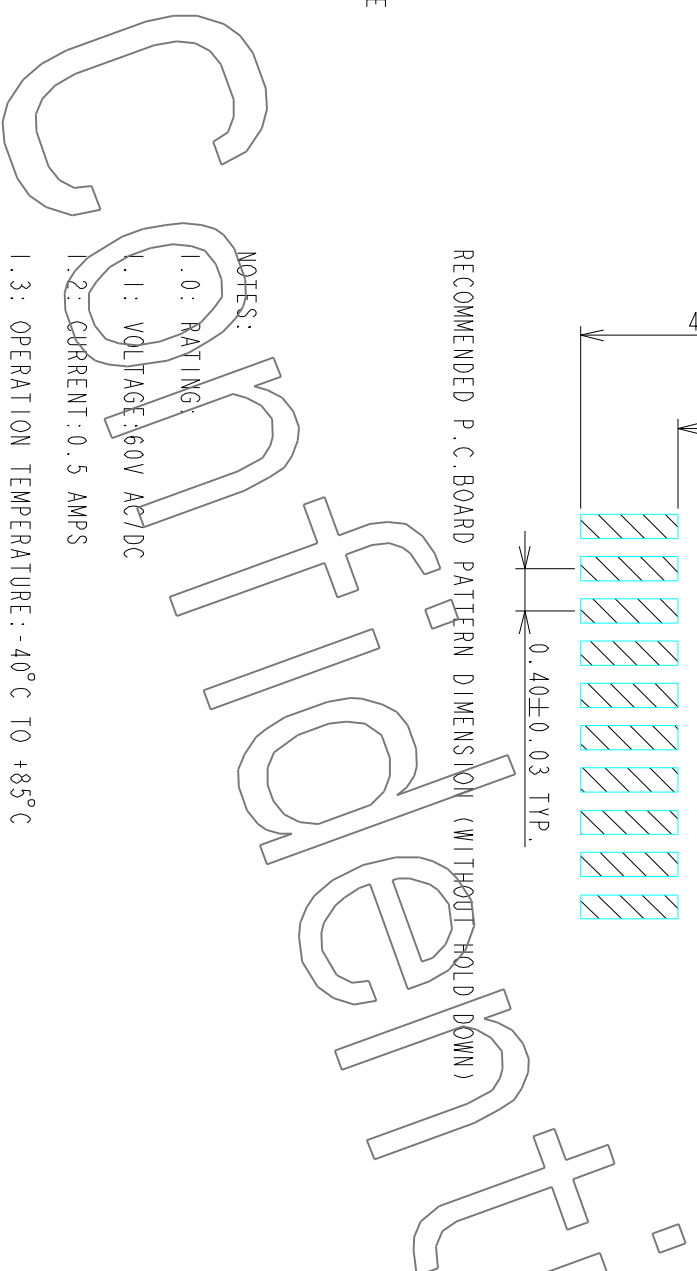
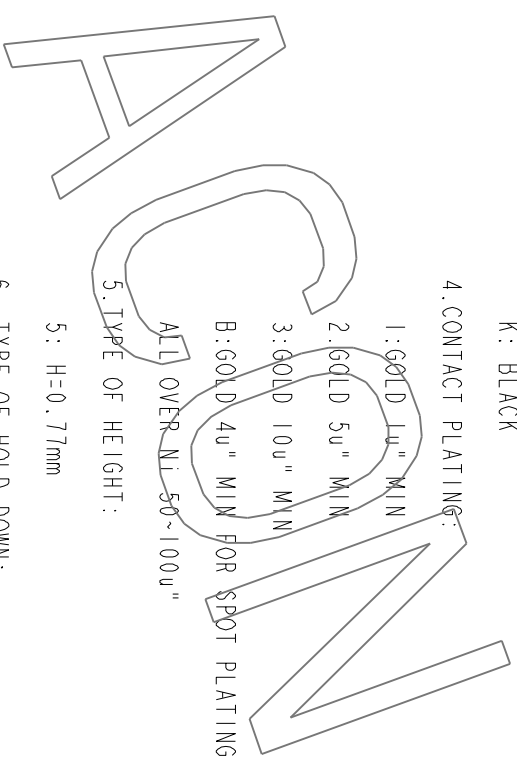

TOLERANCES UNLESS OTHERWISE SPECIFIED		DRAWN		DATE	
GENERAL X	±0.38	RAIN	04/15/10		
M	±0.13	DESIGN			
XX	±0.05	RAIN	04/15/10		
ANGLES X°	±3.0°	CHECKED			
M	±2.0°	HARDWARE	04/24/10		
M	±1.0°	APPROVED			
SCALE 20:1		DICK. LEE	04/24/10		
SHEET 2 OF 2					
UNIT	MM	<b>CUSTOMER DRAWING</b>		SERIES	BBR
				DWG NO.	C-BBR43-04-01
				REV.	B



TITLE  
 P0.4\*H1.0mm BOARD TO BOARD  
 CONN. RECEPTACLE  
 WITHOUT HOLD DOWN

## Kameraanwendungen



Autopilot



Live-Streaming



Videokonferenz



Biometrische Eye-Tracker-Erkennung

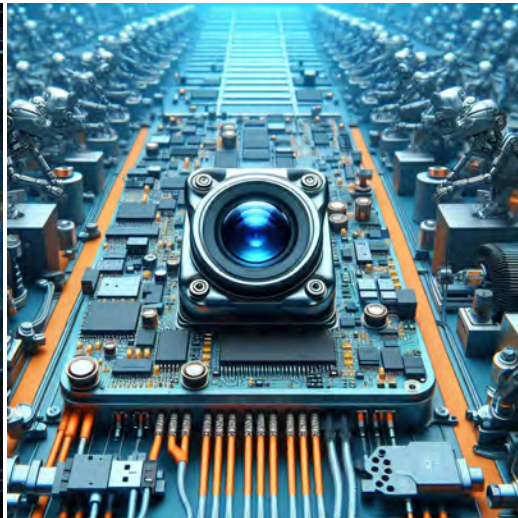

Maschinelles Sehen



Agrarmonitor



Nachtsichtsicherheit



Drohnen- und Sport-Adleraugen



Interaktive Haustierkamera



## Referenztable für die Pinbelegungsdefinition des Kameramoduls

OmniVision Sony Himax Samsung On-Semi Aptina Himax GalaxyCore PixArt Bildsensoren	
Pin Signal	Beschreibung
DGND GND	Masse für digitale Schaltung
AGND	Masse für analoge Schaltung
PCLK DCK	DVP-PCLK-Ausgang
XCLR PWDN XSHUTDOWN STANDBY	Abschalten aktiv hoch mit internem Pulldown-Widerstand
MCLK XVCLK XCLK INCK	Systemeingangsuhr
RESET RST	Aktiv Low mit internem Pull-up-Widerstand zurücksetzen
NC NULL	keine Verbindung
SDA SIO_D SIOD	SCCB-Daten
SCL SIO_C SOIC	SCCB-Eingangstakt
VSYNC XVS FSYNC	DVP-VSYNC-Ausgang
HREF XHS	DVP-HREF-Ausgang
DOVDD	Strom für E/A-Schaltung
AFVDD	Strom für VCM-Schaltung
AVDD	Strom für analoge Schaltung
DVDD	Strom für digitale Schaltung
STROBE FSTROBE	Strobe-Ausgang
FSIN	Synchronisieren Sie das VSYNC-Signal vom anderen Sensor
SID	SCCB letzte Bit-ID-Eingabe
ILPWM	mechanische Shutter-Ausgangsanzeige
FREX	Rahmenbelichtung / mechanischer Verschluss
GPIO	Allzweckeingänge
SLASEL	I2C-Slave-Adresse auswählen
AFEN	CEN-Chip aktivieren aktiv hoch auf VCM-Treiber-IC
<b>MIPI Schnittstelle</b>	
MDN0 DN0 MD0N DATA_N DMO1N	MIPI 1st negative Ausgabe der Datenspur
MDP0 DP0 MD0P DATA_P DMO1P	MIPI 1st positiver Ausgang der Datenspur
MDN1 DN1 MD1N DATA2_N DMO2N	MIPI 2nd negative Ausgabe der Datenspur
MDP1 DP1 MD1P DATA2_P DMO2P	MIPI 2nd positiver Ausgang der Datenspur
MDN2 DN2 MD2N DATA3_N DMO3N	MIPI 3rd negative Ausgabe der Datenspur
MDP2 DP2 MD2P DATA3_P DMO3P	MIPI 3rd positiver Ausgang der Datenspur
MDN3 DN3 MD3N DATA4_N DMO4N	MIPI 4th negative Ausgabe der Datenspur
MDP3 DP3 MD3P DATA4_P DMO4P	MIPI 4th positiver Ausgang der Datenspur
MCN CLKN CLK_N DCKN	MIPI Uhr negativer Ausgang
MCP CLKP MCP CLK_P DCKN	MIPI Takt positiver Ausgang
<b>DVP Parallel Schnittstelle</b>	
D0 DO0 Y0	DVP Datenausgabeport 0
D1 DO1 Y1	DVP Datenausgabeport 1
D2 DO2 Y2	DVP Datenausgabeport 2
D3 DO3 Y3	DVP Datenausgabeport 3
D4 DO4 Y4	DVP Datenausgabeport 4
D5 DO5 Y5	DVP Datenausgabeport 5
D6 DO6 Y6	DVP Datenausgabeport 6
D7 DO7 Y7	DVP Datenausgabeport 7
D8 DO8 Y8	DVP Datenausgabeport 8
D9 DO9 Y9	DVP Datenausgabeport 9
D10 DO10 Y10	DVP Datenausgabeport 10
D11 DO11 Y11	DVP Datenausgabeport 11

## Kamera-Zuverlässigkeitstest

Zuverlässigkeitsprüfpunkt		Testmethode	Akzeptanzkriterium	
Kategorie	Artikel			
Umwelt	Lager Temperatur	Hoch 60°C 96 Std	Temperaturkammer	Keine anormale Situation
		Niedrig -20°C 96 Std	Temperaturkammer	Keine anormale Situation
	Betriebs Temperatur	Hoch 60°C 24 Std	Temperaturkammer	Keine anormale Situation
		Niedrig -20°C 24 Std	Temperaturkammer	Keine anormale Situation
	Feuchtigkeit	60°C 80% 24 Std	Temperaturkammer	Keine anormale Situation
	Thermischer Schock	Hoch 60°C 0.5 Std Niedrig -20°C 0.5 Std Radfahren rein 24 Std	Temperaturkammer	Keine anormale Situation
Physisch	Falltest (Im freien Fall)	Ohne Verpackung 60cm	10 Mal auf Holzboden	Elektrisch funktionsfähig
		Mit Paket 60cm	10 Mal auf Holzboden	Elektrisch funktionsfähig
	Vibrations Test	50Hz X-Axis 2mm 30 Minuten	Vibrationstisch	Elektrisch funktionsfähig
		50Hz Y-Axis 2mm 30 Minuten	Vibrationstisch	Elektrisch funktionsfähig
		50Hz Z-Axis 2mm 30 Minuten	Vibrationstisch	Elektrisch funktionsfähig
	Zugfestigkeit des Kabels Krafttest	Gewicht laden 4 kg 60 Sekunden Radfahren rein 24 Std	Zugprüfmaschine	Elektrisch funktionsfähig
Elektrisch	ESD-Test	Kontaktaufnahme 2 KV	ESD-Prüfmaschine	Elektrisch funktionsfähig
		Luftentladung 4 KV	ESD-Prüfmaschine	Elektrisch funktionsfähig
	Alterungstest	On/Off 30 Sekunden Radfahren rein 24 Std	Stromschalter	Elektrisch funktionsfähig
	USB-Anschluss	On/Off 250 Mal	Einstecken und ausstecken	Elektrisch funktionsfähig



## Kamerainspektionsstandard

Inspektionsgegenstand		Untersuchungsmethode	Inspektionsstandard	
Kategorie	Artikel			
Aussehen	FPC oder PCB	Farbe	Das bloße Auge	Größere Unterschiede sind nicht zulässig.
		Zerrissen/gehackt werden	Das bloße Auge	Das Freilegen von Kupferrissen ist nicht zulässig.
		Markierung	Das bloße Auge	Klar, erkennbar (innerhalb von 30 cm Entfernung)
	Halterin	Kratzer	Das bloße Auge	Die Freilegung von Rissen im Inneren ist nicht zulässig
		Lücke	Das bloße Auge	Erfüllen Sie den Höhenstandard
		Schraube	Das bloße Auge	Stellen Sie sicher, dass Schrauben vorhanden sind (falls vorhanden)
		Schaden	Das bloße Auge	Die Freilegung von Rissen im Inneren ist nicht zulässig
	Linse	Kratzen	Das bloße Auge	Keine Auswirkung auf den Auflösungsstandard
		Kontamination	Das bloße Auge	Keine Auswirkung auf den Auflösungsstandard
		Ölfilm	Das bloße Auge	Keine Auswirkung auf den Auflösungsstandard
		Abdeckband	Das bloße Auge	Kein Problem beim Aussehen.
	Funktion	Bild	Keine Kommunikation	Testboard
Helles Pixel			Tafel	Im Image Center nicht erlaubt
Dunkles Pixel			Weißer Tafel	Im Image Center nicht erlaubt
Verschwommen			Das bloße Auge	Nicht erlaubt
Kein Bild			Das bloße Auge	Nicht erlaubt
Vertikale Linie			Das bloße Auge	Nicht erlaubt
Horizontale Linie			Das bloße Auge	Nicht erlaubt
Kleines Leck			Das bloße Auge	Nicht erlaubt
Blinkendes Bild			Das bloße Auge	Nicht erlaubt
Prellung			Inspektionslehre	Nicht erlaubt
Auflösung			Diagramm	Folgt dem Diagrammstandard für ausgehende Inspektionen
Farbe			Das bloße Auge	Kein Problem
Lärm			Das bloße Auge	Nicht erlaubt
Ecke dunkel			Das bloße Auge	Weniger als 100 x 100 Pixel
Farbauflösung			Das bloße Auge	Kein Problem
Abmessungen	Höhe	Das bloße Auge	Befolgt Zulassungsdatenblatt	
	Breite	Das bloße Auge	Befolgt Zulassungsdatenblatt	
	Länge	Das bloße Auge	Befolgt Zulassungsdatenblatt	
	Gesamt	Das bloße Auge	Befolgt Zulassungsdatenblatt	



## YDSCAM Paketlösungen

YDSCAM Kameramodul



Komplett mit Linsenschutzfolie



Tablett mit Gitter und Raum



Legen Sie die Kameras auf das Tablett



## YDSCAM Paketlösungen

Volles Fach mit Kameras



Decken Sie das Tablett mit dem Deckel ab



Legen Sie das Tablett in den antistatischen Beutel



Staubsaugen Sie den antistatischen Beutel



## YDSCAM Paketlösungen

Versiegelter antistatischer Vakuumbbeutel mit Etiketten

1. Modell und Beschreibung 2. Menge 3. Herstellungsdatumscode 4. Achtung



## YDSCAM Paketlösungen

Legen Sie Schaumstoffplatten zwischen die Tablettbeutel



Schaumstoffplatten sind größer als Tablett



Legen Sie Schaumstoffplatten und Tablett in den Karton



Die Schaumstoffplatten sitzen fest im Karton



Verschließen Sie die Carbon Box



Beschriften Sie den Carbon-Versandkarton



## YDSCAM Paketlösungen

USB-Kameramodul

Komplett mit Objektivschutzfolie

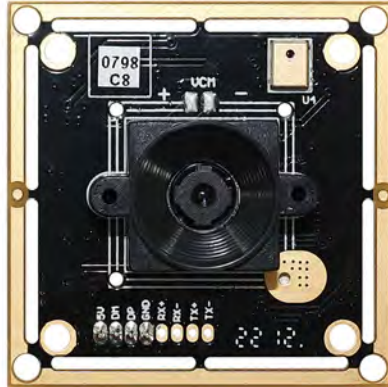

Legen Sie die Kameraprobe in den antistatischen Beutel

Legen Sie USB-Kameras in das Fach



Verschließen Sie das Tablett mit einem antistatischen Beutel

Beschriften Sie den Carbon-Versandkarton



## YDSCAM Paketlösungen

Legen Sie die Kameraprobe in den antistatischen Beutel



Legen Sie die Steckverbinder in den antistatischen Beutel



Beschriften Sie die Probenbeutel



Stecken Sie die Steckverbinder in die Spule



Legen Sie Proben in die Carbonbox



Stecken Sie die Steckverbinder in die Carbonbox





## Firma YDSCAM

YingDeShun Co. Ltd. (YDS) wurde 2017 gegründet, ein technologieorientierter Hersteller der nächsten Generation, der sich auf Forschung, Design und Produktion von Audio- und Videoprodukten spezialisiert hat. YDS verfügt über 20.000 Quadratmeter große automatisierte Anlagen mit 100 Mitarbeitern und einem Jahresdurchsatz von 30.000.000 Kameraeinheiten.

YDS bietet OEM- und ODM-Design sowie Auftragsfertigung und baut die Kameraprodukte. Sie können uns die Anforderungen mitteilen, sogar mit einem Handentwurf. Unser Vertrieb und unsere Technik arbeiten zusammen, um Ihre Anforderungen zu erfüllen. Wir verstehen uns als Ihr langfristiger Partner bei der Entwicklung praktischer und innovativer Lösungen.

Unser Team deckt alles von der ersten Konzeptentwicklung bis zum Massenprodukt ab. YDS ist auf kundenspezifisches Kameradesign, Rohmaterial, Elektroniktechnik, Firmware-/Softwareentwicklung, Produkttests und Verpackungsdesign spezialisiert. Unsere erfahrenen strategischen Liefersysteme bieten eine robuste und zuverlässige Fertigungskapazität für Aufträge unterschiedlicher Größe.

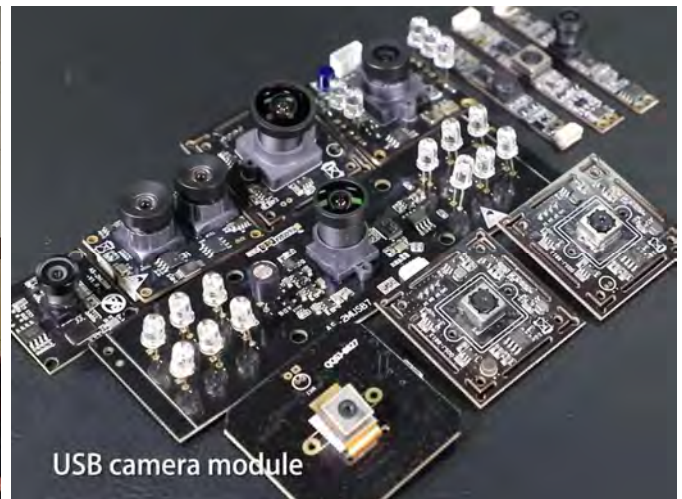

## Eingeschränkte Garantie

YDS gewährt die folgende eingeschränkte Garantie, wenn Sie das/die Produkt(e) direkt von der YDS-Firma oder über die YDS-Website [www.YDSCAM.com](http://www.YDSCAM.com) erworben haben. Von anderen Verkäufern oder Quellen gekaufte Produkte fallen nicht unter diese eingeschränkte Garantie. YDS garantiert, dass die Produkte bei normalem Gebrauch für einen Zeitraum von einem (1) Jahr ab dem Datum, an dem Sie das Produkt erhalten („Garanzzeitraum“), frei von Material- und Verarbeitungsfehlern sind.

Für alle Produkte, die während der Garanzzeit wesentliche Material- oder Verarbeitungsfehler aufweisen oder entwickeln, wird YDS nach eigenem Ermessen entweder: (i) das/die Produkt(e) reparieren; (ii) das/die Produkt(e) durch ein/e neue oder generalüberholte(n) Produkt(e) ersetzen (wobei das/die Ersatzprodukt(e) vom identischen Modell oder einer gleichwertigen Funktion sein müssen); oder (iii) Ihnen eine Rückerstattung des Preises gewähren, den Sie für das/die Produkt(e) bezahlt haben.

Diese eingeschränkte Garantie von YDS beschränkt sich ausschließlich auf Reparatur und/oder Ersatz gemäß den oben dargelegten Bedingungen. YDS ist nicht zuverlässig oder verantwortlich für etwaige Folgeereignisse.





# YDS CAMERA MODULE

*your best camera partner*

## Unsere Unternehmensstärke

Leistungsstarke Fabrik



## Professioneller Service



## Versprochene Lieferung



[www.YDSCAM.com](http://www.YDSCAM.com) [sales@ydscam.com](mailto:sales@ydscam.com) Phone (WeChat, QQ): (+86) 177 2732 6718

All rights reserved @ YingDeShun Co. Ltd. Specifications subject to change without notice.